

The **profile damper type TA** from the innovative ACE TUBUS series is a maintenance-free, self-contained damping element made from a special Co-Polyester Elastomer. As a result of the degressive damping characteristic it provides a high energy absorption at the beginning of its stroke. The excellent temperature characteristic of the material provides consistent damping performance over a temperature of -40 °C to 90 °C. The low installed weight, the economic price and the long operating life of up to 1 million cycles make this an attractive alternative to hydraulic end position damping, if the moving mass does not have to stop in an exact datum position and it is not necessary to absorb 100 % of the incoming energy. The **space-saving package size** ranges from Ø 12 mm up to Ø 116 mm and is very simply and quickly installed with the supplied specially stepped mounting screw. The TA series have been specially developed to provide **maximum energy capacity** in the **minimum mounting space** in the capacity range from 2 Nm up to 2014 Nm.

Life expectancy is extremely high; **up to twenty times** longer than for urethane dampers, up to **ten times** longer than rubber bumpers and up to **five times** longer than steel springs.

Calculation and selection to be approved by ACE.



Impact velocity range: Up to max. 5 m/s

Environment: Resistant to oil, grease, seawater and to microbe or chemical attack. Excellent UV and ozone resistance. Material does not absorb water or swell.

Mounting: In any position

Dynamic force range: 870 N to 81 700 N

Operating temperature range: -40 °C to 90 °C

Energy absorption: 40% to 66%

Material hardness rating:
Shore 55D

Max. torque:

M3: 2 Nm

M4: 4 Nm

M5: 6 Nm

M6: 10 Nm

M8: 25 Nm

M12: 85 Nm

M16: 210 Nm

On request: Special strokes, -characteristics, -spring rates, -sizes and -materials.



Ordering Example

TUBUS Axial _____ ↑ ↑ ↑ TA37-16
 Outer-Ø 37 mm _____ ↑ ↑ ↑
 Stroke 16 mm _____ ↑ ↑ ↑

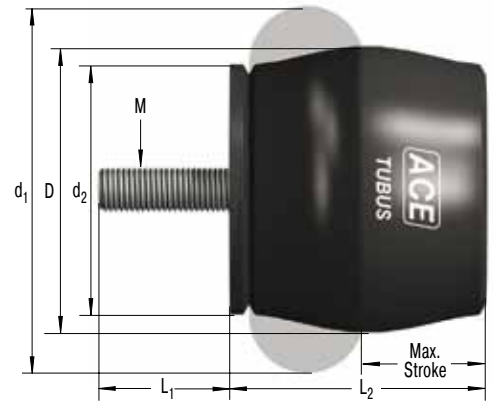

The calculation and selection of the required profile damper should be carried out or be approved by ACE.

Characteristics of Type TA37-16

Energy-Stroke Characteristic (dynamic)
(with impact velocity over 0.5 m/s)

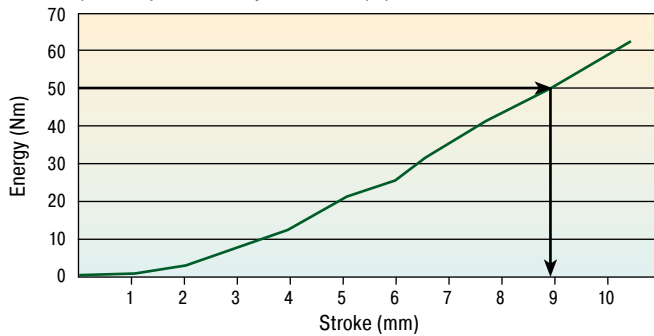

Force-Stroke Characteristic (dynamic)
(with impact velocity over 0.5 m/s)

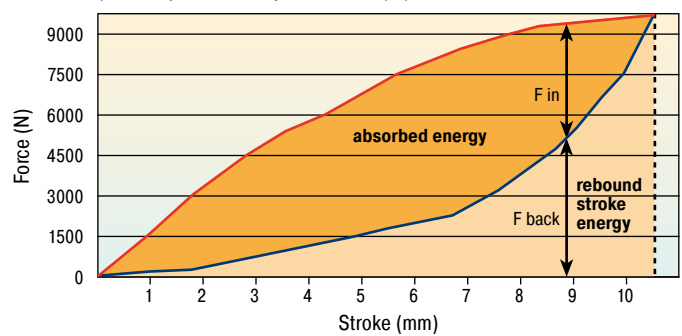

With the aid of the characteristic curves above you can estimate the proportion of the total energy that will be absorbed.
 Example: With impact energy of 50 Nm the Energy-Stroke diagram shows that a stroke of about 8.8 mm is needed.
 On the Force-Stroke diagram you can estimate the proportion of absorbed energy to rebound energy at this stroke length.

Dynamic ($v > 0.5$ m/s) and static ($v \leq 0.5$ m/s) characteristics of all types are available on request.

Dimensions and Capacity Chart

Type	¹ W ₃		Max. Stroke mm	D	L ₁	M	L ₂	d ₁	d ₂	Weight kg
	Nm/Cycle	Nm/Cycle								
TA12-5	2	3	5	12	3	M3	11	15	11	0.001
TA17-7	6	9	7	17	4	M4	16	22	15	0.004
TA21-9	10	16	9	21	5	M5	18	26	18	0.007
TA22-10	11.5	21	10	22	6	M6	19	27	19	0.008
TA28-12	29	46	12	28	6	M6	26	36	25	0.016
TA34-14	48	87	14	34	6	M6	30	43	30	0.024
TA37-16	65	112	16	37	6	M6	33	48	33	0.031
TA40-16	82	130	16	40	8	M8	35	50	34	0.04
TA43-18	112	165	18	43	8	M8	38	55	38	0.051
TA47-20	140	173	20	47	12	M12	41	60	41	0.08
TA50-22	170	223	22	50	12	M12	45	64	44	0.085
TA54-22	201	334	22	54	12	M12	47	68	47	0.1
TA57-24	242	302	24	57	12	M12	51	73	50	0.116
TA62-25	304	361	25	62	12	M12	54	78	53	0.132
TA65-27	374	468	27	65	12	M12	58	82	57	0.153
TA70-29	421	524	29	70	12	M12	61	86	60	0.174
TA72-31	482	559	31	72	16	M16	65	91	63	0.257
TA80-32	570	831	32	80	16	M16	69	100	69	0.312
TA82-35	683	921	35	82	16	M16	74	105	72	0.351
TA85-36	797	1 043	36	85	16	M16	76	110	75	0.391
TA90-38	934	1 249	38	90	16	M16	80	114	78	0.414
TA98-40	1 147	1 555	40	98	16	M16	86	123	85	0.513
TA116-48	2 014	2 951	48	116	16	M16	101	146	98	0.803

¹ Max. energy capacity per cycle for continuous use.

² Energy capacity per cycle for emergency use.

The **profile damper type TS** from the innovative ACE TUBUS series is a maintenance-free, self-contained damping element made from a special Co-Polyester Elastomer. As a result of the almost linear damping characteristic it provides a very smooth energy absorption with minimum reaction loads on the machine. The excellent temperature characteristic of the material provides consistent damping performance over a temperature of -40 °C to 90 °C. The low installed weight, the economic price and the long operating life of up to 1 million cycles make this an attractive alternative to hydraulic end position damping, if the moving mass does not have to stop in an exact datum position and it is not necessary to absorb 100% of the incoming energy. The **space saving package size** ranges from Ø 14 mm up to Ø 107 mm and is very simply and quickly installed with the supplied specially stepped mounting screw. The TS series have been specially developed to provide **maximum energy capacity** in the **minimum mounting space** in the capacity range from 2 Nm up to 902 Nm.

Life expectancy is extremely high; **up to twenty times** longer than for urethane dampers, **up to ten times** longer than rubber bumpers and **up to five times** longer than steel springs.

Calculation and selection to be approved by ACE.



Impact velocity range: Up to max. 5 m/s

Environment: Resistant to oil, grease, seawater and to microbe or chemical attack. Excellent UV and ozone resistance. Material does not absorb water or swell.

Mounting: In any position

Dynamic force range: 533 N to 22 180 N

Operating temperature range:
-40 °C to 90 °C

Energy absorption: 26% to 56%

Material hardness rating:
Shore 40D

Max. torque:

M4: 4 Nm
M5: 6 Nm
M6: 10 Nm
M12: 85 Nm
M16: 210 Nm

On request: Special strokes, -characteristics, -spring rates, -sizes and -materials.



Ordering Example

TUBUS Axial Soft _____ **TS44-23**
 Outer-Ø 44 mm _____
 Stroke 23 mm _____

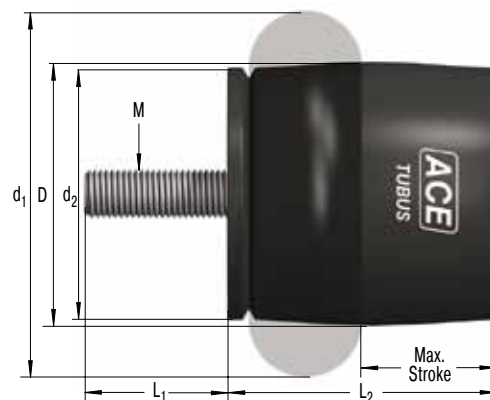

The calculation and selection of the required profile damper should be carried out or be approved by ACE.

Characteristics of Type TS44-23

Energy-Stroke Characteristic (dynamic)
(with impact velocity over 0.5 m/s)

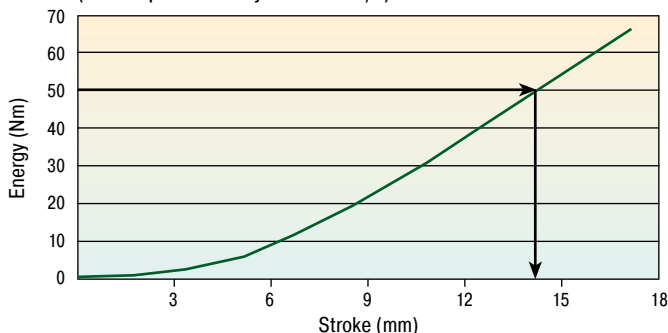

Force-Stroke Characteristic (dynamic)
(with impact velocity over 0.5 m/s)

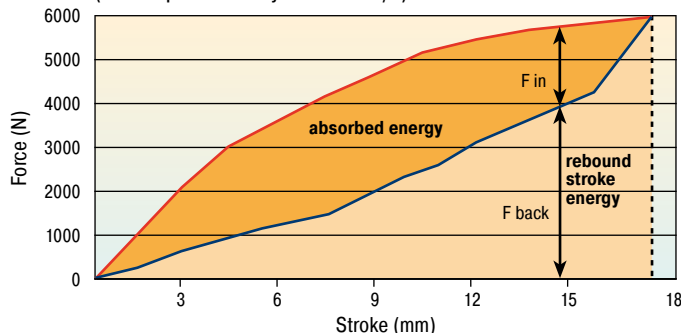

With the aid of the characteristic curves above you can estimate the proportion of the total energy that will be absorbed.
 Example: With impact energy of 50 Nm the Energy-Stroke diagram shows that a stroke of about 14 mm is needed.
 On the Force-Stroke diagram you can estimate the proportion of absorbed energy to rebound energy at this stroke length.

Dynamic ($v > 0.5$ m/s) and static ($v \leq 0.5$ m/s) characteristics of all types are available on request.

Dimensions and Capacity Chart

Type	¹ W ₃		Max. Stroke mm	D	L ₁	M	L ₂	d ₁	d ₂	Weight kg
	Nm/Cycle	Nm/Cycle								
TS14-7	2	3	7	14	4	M4	15	19	13	0.003
TS18-9	4	6	9	18	5	M5	18	24	16	0.006
TS20-10	6	7	10	20	6	M6	21	27	19	0.008
TS26-15	11.5	15	15	26	6	M6	28	37	25	0.015
TS32-16	23	26	16	32	6	M6	32	44	30	0.021
TS35-19	30	36	19	35	6	M6	36	48	33	0.028
TS40-19	34	42	19	40	6	M6	38	51	34	0.031
TS41-21	48	63	21	41	12	M12	41	55	38	0.051
TS44-23	63	72	23	44	12	M12	45	60	40	0.072
TS48-25	81	91	25	48	12	M12	49	64	44	0.086
TS51-27	92	114	27	51	12	M12	52	69	47	0.102
TS54-29	122	158	29	54	12	M12	55	73	50	0.116
TS58-30	149	154	30	58	12	M12	59	78	53	0.132
TS61-32	163	169	32	61	16	M16	62	83	56	0.203
TS64-34	208	254	34	64	16	M16	66	87	60	0.233
TS68-36	227	272	36	68	16	M16	69	92	63	0.248
TS75-39	291	408	39	75	16	M16	75	101	69	0.301
TS78-40	352	459	40	78	16	M16	79	105	72	0.339
TS82-44	419	620	44	82	16	M16	84	110	75	0.346
TS84-43	475	635	43	84	16	M16	85	115	78	0.402
TS90-47	580	778	47	90	16	M16	92	124	84	0.49
TS107-56	902	966	56	107	16	M16	110	147	100	0.733

¹ Max. energy capacity per cycle for continuous use.

² Energy capacity per cycle for emergency use.

The **profile damper type TR** from the innovative ACE TUBUS series is a maintenance-free, self-contained damping element made from a special Co-Polyester Elastomer. The radial deformation of the TR series provides a very long and soft deceleration with a progressive energy absorption towards the end of stroke. The excellent temperature characteristic of the material provides consistent damping performance over a temperature of -40 °C to 90 °C. The low installed weight, the economic price and the long operating life of up to 1 million cycles make this an attractive alternative to hydraulic end position damping, if the moving mass does not have to stop in an exact datum position and it is not necessary to absorb 100% of the incoming energy. The **space saving package size** ranges from Ø 29 mm up to Ø 100 mm and is very simply and quickly installed with the supplied special stepped mounting screw. The TR series have been specially developed to provide **maximum stroke** in the **minimum mounting space** in the capacity range from 1.2 Nm up to 115 Nm.

Life expectancy is extremely high; **up to twenty times** longer than for urethane dampers, **up to ten times longer** than rubber bumpers and **up to five times** longer than steel springs.

Calculation and selection to be approved by ACE.



Impact velocity range: Up to max. 5 m/s

Environment: Resistant to oil, grease, seawater and to microbe or chemical attack. Excellent UV and ozone resistance. Material does not absorb water or swell.

Mounting: In any position

Dynamic force range:
218 N to 5660 N

Operating temperature range:
-40 °C to 90 °C

Energy absorption: 17% to 35%

Material hardness rating:
Shore 40D

Max. torque:
M5: 6 Nm
M6: 10 Nm
M8: 25 Nm

On request: Special strokes, -characteristics, -spring rates, -sizes and -materials.



Ordering Example

TUBUS Radial _____ ↑ ↑ ↑
 Outer-Ø 93 mm _____ ↑ ↑ ↑
 Stroke 57 mm _____ ↑ ↑ ↑

TR93-57

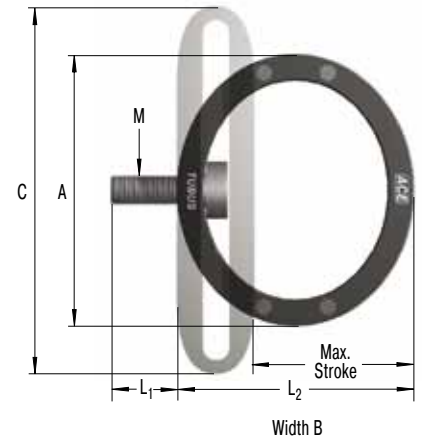

The calculation and selection of the required profile damper should be carried out or be approved by ACE.

Characteristics of Type TR93-57

Energy-Stroke Characteristic (dynamic)
 (with impact velocity over 0.5 m/s)

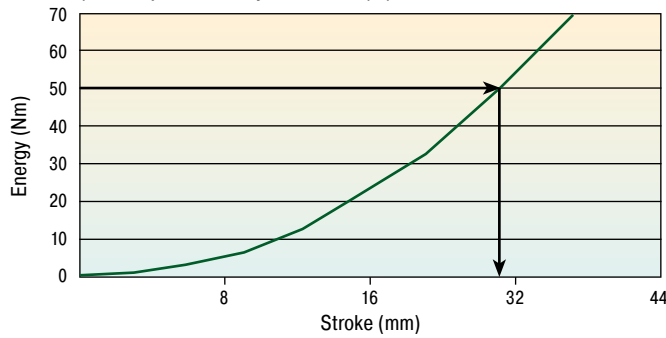

Force-Stroke Characteristic (dynamic)
 (with impact velocity over 0.5 m/s)

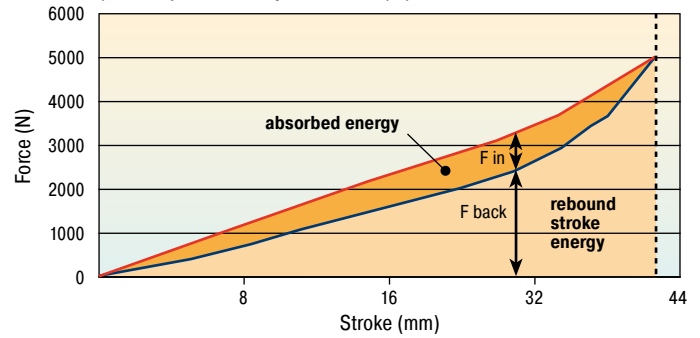

With the aid of the characteristic curves above you can estimate the proportion of the total energy that will be absorbed.
 Example: With impact energy of 50 Nm the Energy-Stroke diagram shows that a stroke of about 31 mm is needed.
 On the Force-Stroke diagram you can estimate the proportion of absorbed energy to rebound energy at this stroke length.

Dynamic ($v > 0.5$ m/s) and static ($v \leq 0.5$ m/s) characteristics of all types are available on request.

Dimensions and Capacity Chart

Type	¹ W ₃		Max. Stroke mm	A	L ₁	M	L ₂	B	C	Weight kg
	Nm/Cycle	Nm/Cycle								
TR29-17	1.2	1.8	17	29	5	M5	25	13	38	0.006
TR37-22	2.3	5.4	22	37	5	M5	32	19	50	0.013
TR43-25	3.5	8.1	25	43	5	M5	37	20	58	0.017
TR50-35	5.8	8.3	35	50	5	M5	44	34	68	0.022
TR63-43	12	17	43	63	5	M5	55	43	87	0.051
TR67-40	23	33	40	67	5	M5	59	46	88	0.077
TR76-46	34.5	43	46	76	6	M6	67	46	102	0.104
TR83-50	45	74	50	83	6	M6	73	51	109	0.142
TR85-50	68	92	50	85	8	M8	73	68	111	0.206
TR93-57	92	122	57	93	8	M8	83	83	124	0.297
TR100-60	115	146	60	100	8	M8	88	82	133	0.335

¹ Max. energy capacity per cycle for continuous use.

² Energy capacity per cycle for emergency use.

Like the standard model TR, the **profile damper type TR-H** is used for radial damping and therefore provides a very long and soft deceleration. The profile dampers from the innovative ACE TUBUS series are maintenance-free, self-contained damping elements made from a special Co-Polyester Elastomer. With nearly the same dimensions the TUBUS TR-H type provides a much higher energy absorption due to a harder mixture of materials. The TR-H type completes the TUBUS series between the progressive model type TR and the almost linear type TS. This offers an individual and widely graduated range of damping characteristics within the whole TUBUS series. The excellent temperature characteristic of the material provides consistent damping performance over a temperature of -40 °C to 90 °C. The low installed weight, the economic price and the long operating life of up to 1 million cycles make this an attractive alternative to hydraulic end position damping, if the moving mass does not have to stop in an exact datum position and it is not necessary to absorb 100% of the incoming energy. The **space saving package size** ranges from Ø 30 mm up to Ø 102 mm and is very simply and quickly installed with the supplied special stepped mounting screw. The TR-H series have been specially developed to provide **maximum stroke** in the **minimum mounting space** in the capacity range from 2.7 Nm up to 290 Nm.

Life expectancy is extremely high; **up to twenty times** longer than for urethane dampers, **up to ten times** longer than rubber bumpers and **up to five times** longer than steel springs.

Calculation and selection to be approved by ACE.



Impact velocity range: Up to max. 5 m/s

Environment: Resistant to oil, grease, seawater and to microbe or chemical attack. Excellent UV and ozone resistance. Material does not absorb water or swell.

Mounting: In any position

Dynamic force range:
600 N to 14 400 N

Operating temperature range:
-40 °C to 90 °C

Energy absorption: 39% to 50%

Material hardness rating:
Shore 55D

Max. torque:
M5: 6 Nm
M6: 10 Nm
M8: 25 Nm

On request: Special strokes, -characteristics, -spring rates, -sizes and -materials.



Ordering Example

TUBUS Radial _____ ↑ ↑ ↑
 Outer-Ø 95 mm _____ ↑ ↑ ↑
 Stroke 50 mm _____ ↑ ↑ ↑
 Hard Version _____ ↑ ↑ ↑

TR95-50H

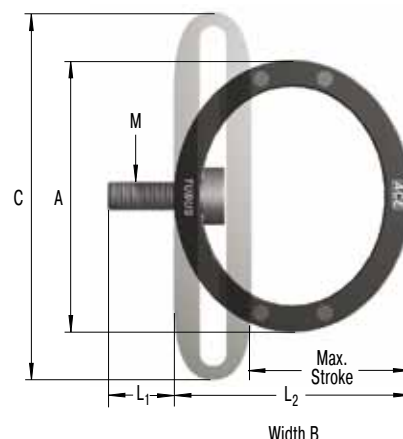

The calculation and selection of the required profile damper should be carried out or be approved by ACE.

Characteristics of Type TR95-50H

Energy-Stroke Characteristic (dynamic)
(with impact velocity over 0.5 m/s)

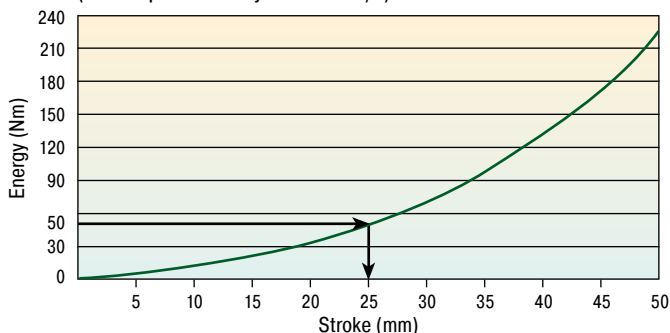

Force-Stroke Characteristic (dynamic)
(with impact velocity over 0.5 m/s)

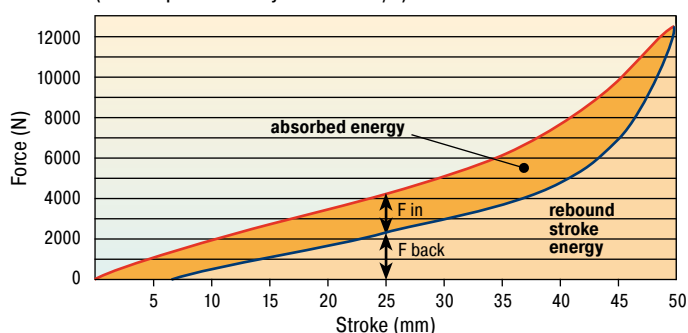

With the aid of the characteristic curves above you can estimate the proportion of the total energy that will be absorbed.
 Example: With impact energy of 50 Nm the Energy-Stroke diagram shows that a stroke of about 25 mm is needed.
 On the Force-Stroke diagram you can estimate the proportion of absorbed energy to rebound energy at this stroke length.

Dynamic ($v > 0.5$ m/s) and static ($v \leq 0.5$ m/s) characteristics of all types are available on request.

Dimensions and Capacity Chart

Type	¹ W ₃		Max. Stroke mm	A	L ₁	M	L ₂	B	C	Weight kg
	Nm/Cycle	Nm/Cycle								
TR30-15H	2.7	5.7	15	30	5	M5	23	13	38	0.004
TR39-19H	6	18	19	39	5	M5	30	19	50	0.011
TR45-23H	8.7	24	23	45	5	M5	36	20	58	0.016
TR52-32H	11.7	20	32	52	5	M5	42	34	68	0.025
TR64-41H	25	46	41	64	5	M5	53	43	87	0.051
TR68-37H	66.5	98	37	68	5	M5	56	46	88	0.080
TR79-42H	81.5	106	42	79	6	M6	64	46	102	0.105
TR86-45H	124	206	45	86	6	M6	69	51	109	0.146
TR87-46H	158	261	46	86	8	M6	68	67	111	0.190
TR95-50H	228	342	50	95	8	M8	77	82	124	0.266
TR102-56H	290	427	56	102	8	M8	84	81	133	0.319

¹ Max. energy capacity per cycle for continuous use.

² Energy capacity per cycle for emergency use.

The **radial tube damper type TR-L** from the innovative ACE TUBUS series is a maintenance-free, self-contained damping element made from a special Co-Polyester Elastomer. The radial deformation of the TR series provides a very long and soft deceleration with a progressive energy absorption towards the end of stroke. The excellent temperature characteristic of the material provides consistent damping performance over a temperature of -40 °C to 90 °C. The tube damper has been specially developed for applications that require very low reaction forces. The actual force generated depends upon the length of the tube damper chosen. The TUBUS TR-L type is suitable for a wide range of applications that require protection from shock or impact anywhere along a straight line. Typical applications include mining equipment, dockyard handling equipment and on baggage handling and conveyor systems. The TR-L series have been developed to provide **maximum stroke** in the **minimum mounting space** in the capacity range from 7.5 Nm up to 7700 Nm.

Life expectancy is extremely high; **up to twenty times** longer than for urethane dampers, up to **ten times** longer than rubber bumpers and up to **five times** longer than steel springs.

Calculation and selection to be approved by ACE.



Impact velocity range: Up to max. 5 m/s

Environment: Resistant to oil, grease, seawater and to microbe or chemical attack. Excellent UV and ozone resistance. Material does not absorb water or swell.

Capacity rating: For emergency use only (1 cycle) it is possible to exceed the W_3 rating by +40 %.

Mounting: In any position

Dynamic force range:
1812 N to 217 700 N

Operating temperature range:
-40 °C to 90 °C

Energy absorption: 14% to 26 %

Material hardness rating:
Shore 40D

Max. torque:

M5: 6 Nm

M8: 25 Nm

M16: 210 Nm

On request: Special strokes, -colours, -sizes and -materials.



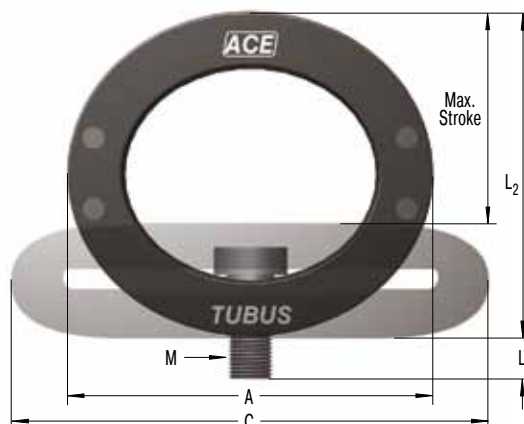
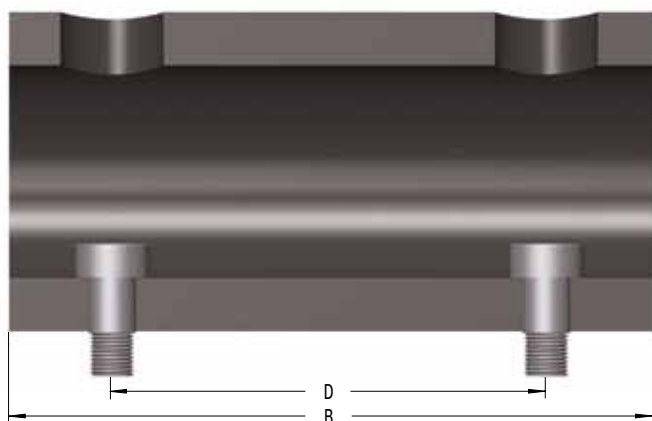

Ordering Example

TUBUS Radial _____ **TR66-40L-2**
 Outer-Ø 66 mm _____
 Stroke 40 mm _____
 Long Version _____
 Length 2 = 305 mm _____

The calculation and selection of the required profile damper should be carried out or be approved by ACE.

Dimensions and Capacity Chart

Type	¹ W ₃ Nm/Cycle	² W ₃ Nm/Cycle	Max. Stroke mm	A	B	C	D	M	L ₁	L ₂	Weight kg
TR29-17L	7.5	10.5	17	29	80	38	40	M5	5	25	0.029
TR43-25L	17	24	25	43	80	58	40	M5	5	37	0.072
TR63-43L	23	32	43	63	80	87	40	M5	5	55	0.106
TR66-40L-1	102	143	40	66	152	87	102	M8	8	59	0.028
TR66-40L-2	204	286	40	66	305	87	254	M8	8	59	0.58
TR66-40L-3	306	428	40	66	457	87	406	M8	8	59	0.83
TR66-40L-4	408	571	40	66	610	87	559	M8	8	59	1.13
TR66-40L-5	510	714	40	66	762	87	711	M8	8	59	1.33
TR76-45L-1	145	203	45	76	152	100	102	M8	8	68	0.38
TR76-45L-2	290	406	45	76	305	100	254	M8	8	68	0.079
TR76-45L-3	435	609	45	76	457	100	406	M8	8	68	1.13
TR76-45L-4	580	812	45	76	610	100	559	M8	8	68	1.43
TR76-45L-5	725	1 015	45	76	762	100	711	M8	8	68	1.78
TR83-48L-1	180	252	48	83	152	106	102	M8	8	73	0.48
TR83-48L-2	360	504	48	83	305	106	254	M8	8	73	0.93
TR83-48L-3	540	756	48	83	457	106	406	M8	8	73	1.38
TR83-48L-4	720	1 008	48	83	610	106	559	M8	8	73	4.83
TR83-48L-5	900	1 260	48	83	762	106	711	M8	8	73	4.83
TR99-60L-1	270	378	60	99	152	130	102	M16	16	88	0.79
TR99-60L-2	540	756	60	99	305	130	254	M16	16	88	1.29
TR99-60L-3	810	1 134	60	99	457	130	406	M16	16	88	1.94
TR99-60L-4	1 080	1 512	60	99	610	130	559	M16	16	88	2.54
TR99-60L-5	1 350	1 890	60	99	762	130	711	M16	16	88	3.1
TR99-60L-6	1 620	2 268	60	99	914	130	864	M16	16	88	3.7
TR99-60L-7	1 890	2 646	60	99	1 067	130	1 016	M16	16	88	4.3
TR143-86L-1	600	840	86	143	152	191	76	M16	16	127	1.44
TR143-86L-2	1 200	1 680	86	143	305	191	203	M16	16	127	2.9
TR143-86L-3	1 800	2 520	86	143	457	191	355	M16	16	127	5.29
TR143-86L-4	2 400	3 360	86	143	610	191	508	M16	16	127	5.29
TR143-86L-5	3 000	4 200	86	143	762	191	660	M16	16	127	6.59
TR143-86L-6	3 600	5 040	86	143	914	191	812	M16	16	127	7.89
TR143-86L-7	4 200	5 880	86	143	1 067	191	965	M16	16	127	9.19
TR188-108L-1	1 100	1 540	108	188	152	245	76	M16	16	165	2.34
TR188-108L-2	2 200	3 080	108	188	305	245	203	M16	16	165	4.64
TR188-108L-3	3 300	4 620	108	188	457	245	355	M16	16	165	6.89
TR188-108L-4	4 400	6 160	108	188	610	245	508	M16	16	165	9.19
TR188-108L-5	5 500	7 700	108	188	762	245	660	M16	16	165	11.39
TR188-108L-6	6 600	9 240	108	188	914	245	812	M16	16	165	13.64
TR188-108L-7	7 700	10 780	108	188	1 067	245	965	M16	16	165	15.94

¹ Max. energy capacity per cycle for continuous use.

² Energy capacity per cycle for emergency use.

The **profile damper type TC** from the innovative ACE TUBUS series is a maintenance-free, self-contained damping element made from a special Co-Polyester Elastomer. They have been specially developed for crane equipment applications and fulfill the international industry standards OSHA and CMAA. Many crane applications require a spring rate with a high return force. This is achieved with the unique **Dual-Profile Concept** of the TC-S models. For energy-management-systems the TC model types provide a cost efficient solution with a high return force capability. The very small and light package size from Ø 64 mm up to Ø 176 mm covers an energy absorption capacity ranging from 450 Nm up to 12 720 Nm/cycle. The excellent resistance to UV, seawater, chemical and microbe attack together with the wide operating temperature range from -40 °C to 90 °C enables a wide range of applications.

Life expectancy is extremely high; **up to twenty times** longer than for urethane dampers, up to **ten times** longer than rubber bumpers and up to **five times** longer than steel springs.

Calculation and selection to be approved by ACE.



Impact velocity range: Up to max. 5 m/s

Environment: Resistant to oil, grease, seawater and to microbe or chemical attack. Excellent UV and ozone resistance. Material does not absorb water or swell.

Capacity rating: For emergency use only (1 cycle) it is possible to exceed the W_3 rating by +40 %.

Mounting: In any position

Dynamic force range:
80 000 N to 978 000 N

Operating temperature range:
-40 °C to 90 °C

Energy absorption: 31 % to 63 %

Material hardness rating:
Shore 55D

Max. torque:
M12: 85 Nm
M16: 210 Nm

On request: Special strokes, -characteristics, -spring rates, -sizes and -materials.



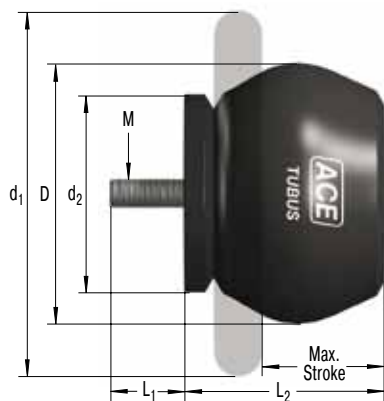

Model Type TC

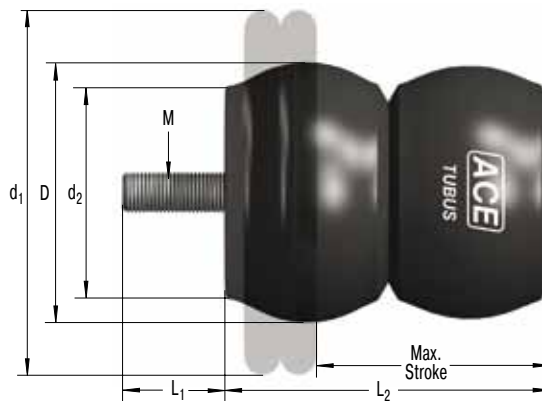

Model Type TC-S

Ordering Example

TUBUS Crane Buffer _____
 Outer-Ø 83 mm _____
 Stroke 73 mm _____
 Model Type Soft _____

TC83-73-S

The calculation and selection of the required profile damper should be carried out or be approved by ACE.

Characteristics of Type TC90-49

Energy-Stroke Characteristic (dynamic)
 (with impact velocity over 0.5 m/s)

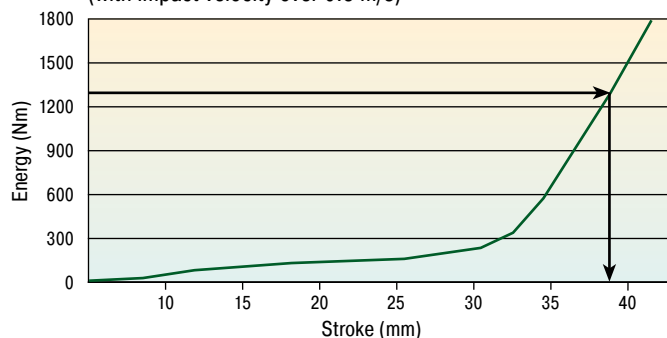

Force-Stroke Characteristic (dynamic)
 (with impact velocity over 0.5 m/s)

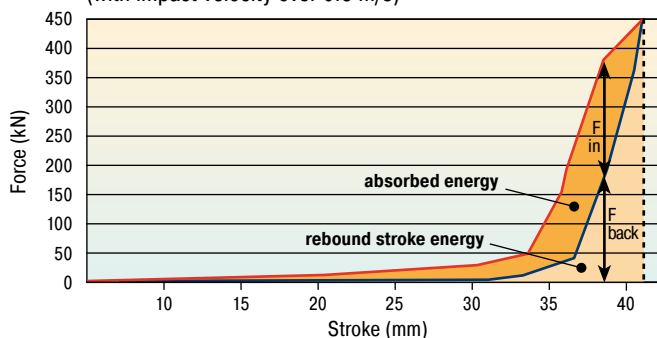

With the aid of the characteristic curves above you can estimate the proportion of the total energy that will be absorbed.

Example: With impact energy of 1300 Nm the Energy-Stroke diagram shows that a stroke of about 38 mm is needed.

On the Force-Stroke diagram you can estimate the proportion of absorbed energy to rebound energy at this stroke length.

Note: With these types the return force towards the end of the stroke is significant and we recommend you try to use a minimum of 90 % of the total stroke available.

Dynamic ($v > 0.5$ m/s) and static ($v \leq 0.5$ m/s) characteristics of all types are available on request.

Dimensions and Capacity Chart

Type	¹ W ₃ Nm/Cycle	² W ₃ Nm/Cycle	Max. Stroke mm	D	L ₁	M	L ₂	d ₁	d ₂	Weight kg
TC64-62-S	450	630	62	64	12	M12	79	89	52	0.175
TC74-76-S	980	1 372	76	74	12	M12	96	114	61	0.261
TC83-73-S	1 940	2 715	73	83	12	M12	94	127	69	0.328
TC86-39	1 210	1 695	39	86	12	M12	56	133	78	0.284
TC90-49	1 640	2 295	49	90	12	M12	68	124	67	0.265
TC100-59	1 785	2 500	59	100	12	M12	84	149	91	0.513
TC102-63	1 970	2 760	63	102	16	M16	98	140	82	0.633
TC108-30	1 900	2 660	30	108	12	M12	53	133	77	0.392
TC117-97	3 710	5 195	97	117	16	M16	129	188	100	1.053
TC134-146-S	7 310	10 230	146	134	16	M16	188	215	117	1.573
TC136-65	4 250	5 950	65	136	16	M16	106	178	106	1.173
TC137-90	6 350	8 890	90	137	16	M16	115	216	113	1.193
TC146-67-S	8 330	11 660	67	146	16	M16	118	191	99	1.573
TC150-178-S	8 860	12 400	178	150	16	M16	241	224	132	2.581
TC153-178-S	7 260	10 165	178	153	16	M16	226	241	131	2.493
TC168-124	10 100	14 140	124	168	16	M16	166	260	147	2.533
TC176-198-S	12 720	17 810	198	176	16	M16	252	279	150	3.591

¹ Max. energy capacity per cycle for continuous use.

² Energy capacity per cycle for emergency use.

Physical Properties of TUBUS Profile Dampers

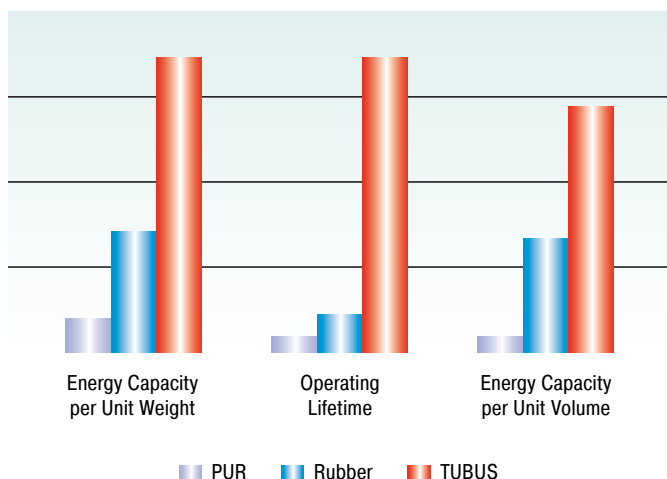

ACE TUBUS profile dampers are high performance damping elements made from a special Co-Polyester Elastomer. They have a high energy absorbing capacity compared with other materials. The TUBUS-series comprises 6 main types with over 120 individual models.

The excellent damping characteristics are achieved as a result of the special elastomer material and the worldwide patented construction design. This enables us to change the characteristics of the elastomer material so that individual and distinct damping curves are possible.

TUBUS dampers offer a considerable performance advantage when compared to other materials such as rubber, urethanes (PUR) and steel springs.

A further advantage compared to other damping elements is the **operating life expectancy – up to twenty times longer than with urethane dampers, up to ten times longer than with rubber dampers and up to five times longer than with steel spring dampers.**

Comparison of Damping Characteristics

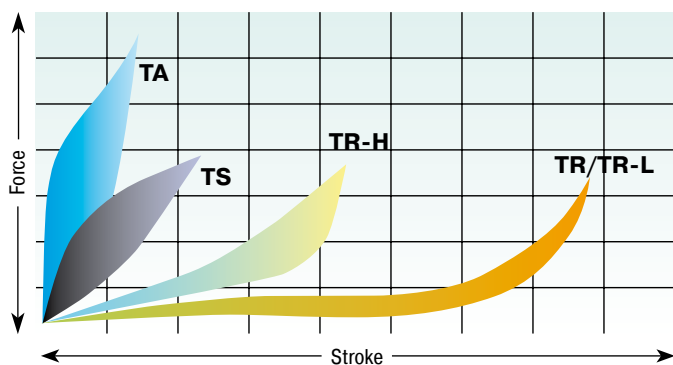

Characteristics of dynamic energy absorption for impact velocity over 0.5 m/s. For impact velocities under 0.5 m/s, please request a static characteristic curve.

The innovative TUBUS dampers absorb energy while exhibiting the following damping characteristics:

Model type TA: Degressive characteristic with max. energy absorption (coloured area) with min. stroke.
Energy absorption: 40 % to 66 %.

Model type TS: Almost linear characteristic with low reaction force over a short operating stroke.
Energy absorption: 26 % to 56 %.

TR/TR-H/TR-L: Progressive characteristic with gradually increasing reaction force over a long stroke.
Energy absorption **TR:** 17 % to 35 %
Energy absorption **TR-H:** 39 % to 50 %
Energy absorption **TR-L:** 14 % to 26 %

The material does not absorb water or swell and it is highly resistant to abrasion. Products of the TUBUS-series will work at **temperatures of -40 °C up to 90 °C** and are resistant to grease, oil, petroleum fluids, microbe and chemical attack and sea water. They also have good UV and ozone resistance. The **very long service life** of up to one million cycles, the **compact size** and the **low unit weight** differentiate the TUBUS profile dampers from all other types of elastomer damping elements.

If you are looking for an economic damping solution where the load does not need to be decelerated to an exact datum position and you do not need 100 % absorption of the impact energy then TUBUS dampers are a real alternative to hydraulic end position damping. They are the preferred solution for end stop dampers in robotic systems, high bay warehouse systems and all similar automated plant and machinery.

For the crane industry we manufacture special **high capacity crane buffers** that have an ideal deceleration characteristic with high return force for this type of application and energy capacities from 450 to 12 720 Nm. This means you can have a TUBUS crane buffer capable of providing up to 900 kN of braking force in a package only weighing 3 kg and absorbing up to 50 % of the energy.

Special Dampers

Besides the standard product range of the TUBUS-series there are also a large number of special products available upon request for customer-specific applications.

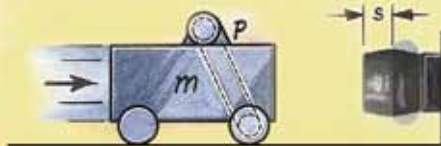

Safe end position damping

ACE TUBUS profile dampers protect the integrated loading station on a new high speed machining centre.

The ACE TUBUS damper is designed to prevent overrun on the high speed loading station of a Camshaft machining centre used in the automobile industry. In the event that the drive train fails during operation or incorrect data is inputted the ACE TUBUS damper absorbs the impact preventing costly damage to the machine. The **TA98-40** TUBUS damper impressed engineers with this exceptionally long service life in operation.

When used as an emergency stop the TUBUS damper can absorb up to 63 % of the impact energy.



Safety with ultra high speed operation

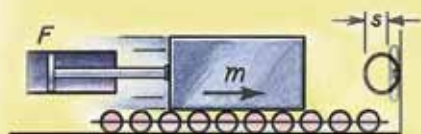

Smooth pivoting

TUBUS profile dampers safeguard hydraulic cylinders.

In a testing facility for vehicle tanks, the test specimens are pulled out of the water with a support arm. A hydraulic cylinder carries out the swinging movement and is attenuated in the end position by two TUBUS **TR85-50**.

Even if this work could be taken over by other absorber solutions, the energy balance clearly speaks for the benefits of the profile dampers – they are inexpensive, they save space, they are free of leaks due to solid construction and are suitable for underwater functions in the test pool.



With the kind permission of Worthmann Maschinenbau GmbH
Economical end position absorption on the hydraulic drive

